

SFP-250 and SFP-400

P-231
819-0382

Installation Instructions



An Altra Industrial Motion Company

Contents

Introduction	2
Installation	3
Maintenance	3
Troubleshooting	4
Specifications	4
Coil Ratings	4
Dimensions	5
Warranty	Back Page

Introduction

The Warner Electric SFP-250 and SFP-400 are shaft mounted stationary field electromagnetic clutches. Designed for simplicity, the units are preburnished at the factory and are ready to install onto the shaft. Once installed, there is no need to make any adjustments for wear, and there are no parts that should need replacing over the natural life of the clutch. With the proper alignment already set by the factory and with no brushes to wear out, the SFP-250 and SFP-400 are assured for dependable, trouble free life.

⚠ WARNING Follow the instructions in this manual carefully to assure proper installation and operation. Failure to do so may result in damage to property and/or injury or even death to personnel.

Installation

1. Check that the unit has arrived in good condition. Each clutch comes with a terminal accessory kit, part number 5103-101-002, containing two screws, two terminal rings, and two rubber terminal caps.
2. Fasten the user supplied pulley or sheave to the clutch armature using the three threaded mounting holes provided. Make sure that the fasteners are short enough so they do not bottom out on the armature. Refer to the Dimensions section for bolt circle and thread information. Use Loctite® 242 or equivalent to help assure thread retention.
3. For the SFP-400 only: To install the optional conduit box, Warner Electric part number 5200-101-010, follow the separate installation instructions provided with the conduit box to assemble it to the clutch.
4. Slide the clutch onto the shaft.

▲CAUTION Be sure the keyway is positioned over the user supplied shaft key.

Alternately tighten the two setscrews to secure the clutch to the shaft. (Depending on the width of the pulley, it may have been necessary to tighten the setscrews before fastening the pulley.)

5. Attach a user supplied flexible strap or band to the tab on the back of the field to secure it to a stationary surface to prevent field rotation.

▲CAUTION The anti-rotation tab on the field should not be rigidly fixed as this could preload the bearing and reduce its life.

6. Make electrical connections from the DC power source to the clutch. Either wire can be attached to the + or - terminal. If a Warner Electric control is used as the power source, follow the connection diagram supplied with the control.

Maintenance

▲CAUTION SFP-250 and SFP-400 are dry friction devices. DO NOT apply oil or lubrication.

If correctly sized and installed, the SFP-250 or SFP-400 should run virtually maintenance free. As with all shaft mounted clutches, the ability to dissipate heat will improve life. Care should be taken to ensure adequate ventilation. For demanding applications where the clutch is being cycled on and off rapidly, high temperatures can lead to accelerated wear. After the friction surfaces undergo a significant amount of wear, the armature may not pull in or the unit will show a reduction in torque carrying capability. Then the clutch will need to be replaced.

The clutch's operating environment can also affect its life. If units are used on machinery where fine, abrasive dust, chips, or grit are dispelled into the atmosphere, shielding the clutch may be necessary for maximum life. Where the clutch is used near gear boxes or transmissions requiring frequent lubrication, means should be provided to protect the friction surfaces from oil and grease to prevent torque loss.

Troubleshooting

If the clutch does not engage, slips, or loses torque, the most likely cause is worn out friction surfaces and the clutch should be replaced. If excessive wear is not the cause, first check the input voltage to the coil. Use a DC voltmeter to check the voltage across the terminals with the power on and the control turned all the way up. For 90 volt units, the reading should fall within the 85-95 volt range. For 24 volt units, 22-26 volts is normal.

Current and resistance checks can be made if necessary. Connect a low range ammeter in series with one coil lead. With maximum power supplied, the current reading should approximate the data in the coil ratings table. To check the resistance, use an ohmmeter with the power off and the circuit open. If a very high or infinite resistance is indicated, the coil is open and the clutch should be replaced.

If the above checks indicate that the proper voltage and current are being supplied to the magnet, mechanical parts should be checked to assure that they are in good operating condition, free of contamination and properly installed.

Specifications

Model	Static Torque	Max. RPM
SFP-250	70 lb.in.	7500
SFP-400	270 lb.in.	5000

Coil Ratings

	SFP-250			SFP-400			
	6	24	90	6	12	24	90
Voltage—DC	6	24	90	6	12	24	90
Resistance 20° C—OHMS	5.0	6.4	1079	2.08	8.41	33.73	474.2
Current—Amperes	1.2	0.314	0.08	2.888	1.426	0.711	0.190
Watts	7.2	7.5	7.51	17.3	17.1	17.0	17.1

Dimensions

SFP-250

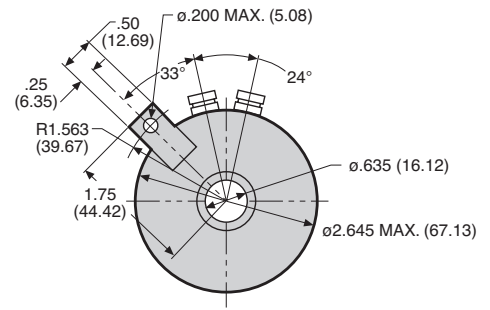
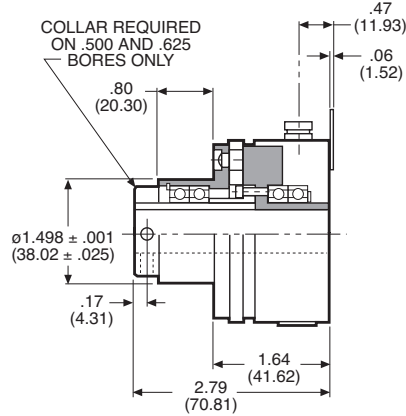
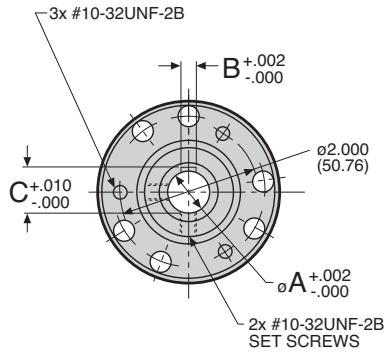

SFP-400

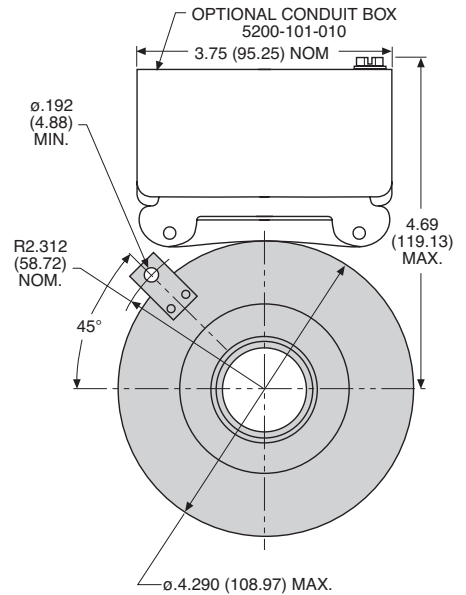
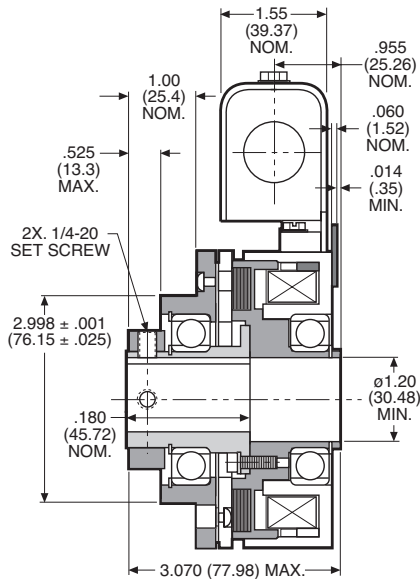
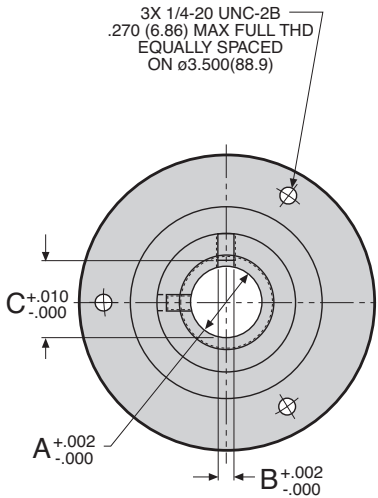

Dimensions

Model No.	A Bore	Keyway		Part Number		
		B	C	6V	24V	90V
SFP-250	.375"	.094	.421	5103-271-002	5103-271-006	5103-271-010
	.438"	.126	.479	5103-271-003	5103-271-007	5103-271-011
	.500"	.126	.560	5103-271-004	5103-271-008	5103-271-012
	.6255"	.1885	.678	5103-271-005	5103-271-009	5103-271-013
SFP-400	.5005"	.125	.560	5104-271-006	5104-271-016	5104-271-021
	.6255"	.187	.709	5104-271-007	5104-271-017	5104-271-022
	.7505"	.187	.837	5104-271-008	5104-271-018	5104-271-023
	.8755"	.187	.964	5104-271-009	5104-271-019	5104-271-024
	1.0005"	.187	1.090	5104-271-010	5104-271-020	5104-271-025

Warranty

Warner Electric LLC warrants that it will repair or replace (whichever it deems advisable) any product manufactured and sold by it which proves to be defective in material or workmanship within a period of one (1) year from the date of original purchase for consumer, commercial or industrial use.

This warranty extends only to the original purchaser and is not transferable or assignable without Warner Electric LLC's prior consent.

Warranty service can be obtained in the U.S.A. by returning any defective product, transportation charges prepaid, to the appropriate Warner Electric LLC factory. Additional warranty information may be obtained by writing the Customer Satisfaction Department, Warner Electric LLC, 449 Gardner Street, South Beloit, Illinois 61080, or by calling 815-389-3771.

A purchase receipt or other proof of original purchase will be required before warranty service is rendered. If found defective under the terms of this warranty, repair or replacement will be made, without charge, together with a refund for transportation costs. If found not to be defective, you will be notified and, with your consent, the item will be repaired or replaced and returned to you at your expense.

This warranty covers normal use and does not cover damage or defect which results from alteration, accident, neglect, or improper installation, operation, or maintenance.

Some states do not allow limitation on how long an implied warranty lasts, so the above limitation may not apply to you.

Warner Electric LLC's obligation under this warranty is limited to the repair or replacement of the defective product and in no event shall Warner Electric LLC be liable for consequential, indirect, or incidental damages of any kind incurred by reason of the manufacture, sale or use of any defective product. Warner Electric LLC neither assumes nor authorizes any other person to give any other warranty or to assume any other obligation or liability on its behalf.

WITH RESPECT TO CONSUMER USE OF THE PRODUCT, ANY IMPLIED WARRANTIES WHICH THE CONSUMER MAY HAVE ARE LIMITED IN DURATION TO ONE YEAR FROM THE DATE OF ORIGINAL CONSUMER PURCHASE. WITH RESPECT TO COMMERCIAL AND INDUSTRIAL USES OF THE PRODUCT, THE FOREGOING WARRANTY IS IN LIEU OF AND EXCLUDES ALL OTHER WARRANTIES, WHETHER EXPRESSED OR IMPLIED BY OPERATION OF LAW OR OTHERWISE, INCLUDING, BUT NOT LIMITED TO, ANY IMPLIED WARRANTIES OF MERCHANTABILITY OR FITNESS.

Some states do not allow the exclusion or limitation of incidental or consequential damages, so the above limitation or exclusion may not apply to you. This warranty gives you specific legal rights and you may also have other rights which vary from state to state.

Changes in Dimensions and Specifications

All dimensions and specifications shown in Warner Electric catalogs are subject to change without notice. Weights do not include weight of boxing for shipment. Certified prints will be furnished without charge on request to Warner Electric.



Warner Electric LLC
449 Gardner Street • South Beloit, IL 61080
815-389-3771 • Fax: 815-389-2582
www.warnerelectric.com
An Altra Industrial Motion Company